



# Outside Air Temperature (OAT) Sensors

## Series 0129

Outside Air Temperature measurement for helicopters, UAV's and general aviation aircraft.

The Series 0129 Outside Air Temperature (OAT) sensors were developed for helicopters and other low-to-moderate airspeed vehicles such as UAV's and general aviation aircraft, where the high speed performance and all-weather capability of our Series 0102 military fighter and commercial transport TAT probes are not required. The Series 0129 OAT sensors offer an affordable alternative to the high performance 0102 TAT probe and the low accuracy immersion temperature probes that were previously the only viable options for low-to-moderate airspeed vehicles.

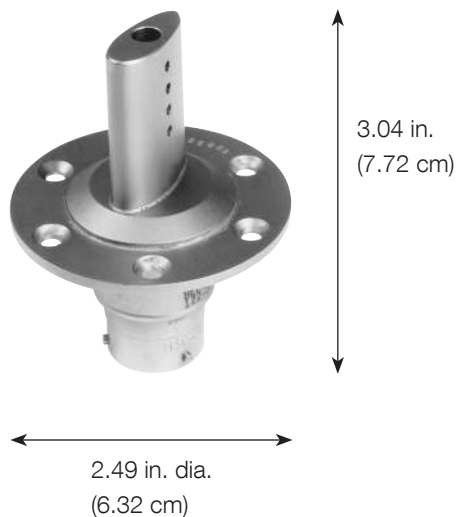

### Features & Benefits

- Single or dual 500 ohm elements
- Passively de-iced design sheds ice build-up without heating

# Outside Air Temperature (OAT) Sensors

## Series 0129

### General Specifications

#### Flight Operating Ranges

Altitude	-1,000 ft. to 60,000 ft. / -304 m to 18,288 m
Mach Number	0 to 0.6
Outside Air Temperature	-85°F to 185°F / -65°C to 85°C

<b>Performance</b>	500 $\pm$ 0.6 ohms at 0°C / 32°F
--------------------	----------------------------------

<b>Temperature Exposure</b>	-94°F to 482°F / -70°C to 250°C
-----------------------------	---------------------------------

### Air Temperature

Modern aircraft require accurate measurements of air temperature for inputs to air data computers and other systems. Static Air Temperature, or SAT, is the temperature of the undisturbed air through which the aircraft is flying. Due to the kinetic energy of the speed of the aircraft, at higher speeds the measured temperature is higher than SAT as that kinetic energy is converted to heat at the sensor. Total Air Temperature, or TAT, is the maximum air temperature that can be attained by 100% conversion of the kinetic energy of the flow. For flight conditions at lower airspeeds (up to approximately Mach 0.4), the 0129 series sensor measures the temperature accurately since the difference between SAT and TAT is small. An error analysis should be performed on the aircraft system in order to determine whether a 0129 series sensor is appropriate for the aircraft flight envelope. If higher accuracy or flows above Mach 0.4 are required, consider a UTC Aerospace Systems Series 0102 Total Air Temperature sensor instead. Contact UTC Aerospace Systems for more details.

This document does not contain any export controlled technical data.

#### For additional information:

UTC Aerospace Systems  
Sensors & Integrated Systems  
14300 Judicial Road  
Burnsville, MN 55306  
U.S.A.  
Tel: +1 952 892 4000  
sis@utas.utc.com

[utcaerospacesystems.com](http://utcaerospacesystems.com)

4101B LIT 7/2015  
© Rosemount Aerospace Inc., 2015

