

ATS AAXICO Technical Services
PMA Product Release

HA225-7ATS Latch Assembly



Installs on:
**Overhead Stowage
Bin Door Assembly**

**B 737 NG
B 757 SERIES**

Because time matters
kapco-global.com



Kapco Global
Aerospace Parts & Distribution Services

The LATCH ASSEMBLY serves as the pull handle and locking device for the door assembly of the overhead stowage bin. The locking mechanism is a single point, hook type latch with a torsion spring for return action for the handle. The hook engages to a keeper or strike type hardware on the inside of the bin. The handle actuates the locking mechanism and the torsion spring returns the handle back to the original position. The handle also has red colored flagging on each end that provides a visual indication that the latch is open. The function of the shroud is as a guard and for aesthetics purposes.

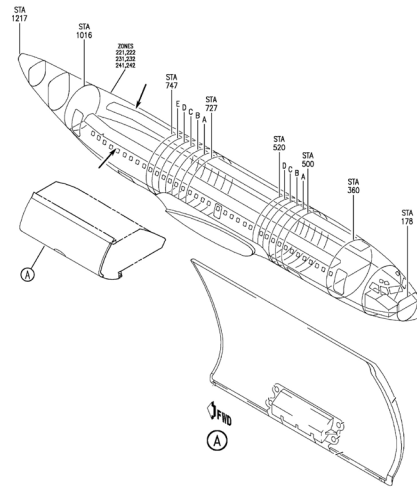

Part Name	ATS PMA P/N	OEM P/N	OEM	ELIGIBILITY
Latch Assembly	HA225-7ATS	HA225-7	Hartwell Corporation	737-600, 700, 700C, 800, 900 Series 757-200, 300 Series

Advantages of Product Improvement:

Offers a substantial cost savings over the OEM part without affecting the original form, fit or function.

Hazmat Statement: Parts manufactured by AAXICO Technical Services do not willfully contain hazardous materials and metals derived from minerals defined as “Conflict Minerals”. These include, but are not limited to, tantalum, tin, tungsten and gold. For more information regarding “Conflict Minerals,” please refer to section 1502 of the Dodd-Frank Act.

US Locations

Corporate Headquarters

+1 714-223-5400

Santa Clarita Facility

+1 661-621-6500

Centerbrook Facility

+1 860-581-5700

Wellington Facility

+1 561-798-6606

Miami Facility

+1 305-592-4633

Europe Locations

France Facility

+33 388 07 26 40

Netherlands Facility

+31 20 655 4330

Spain Facility

+34 648 132 116

United Kingdom Facility

+44 1420 482900

Asia Locations

Singapore Facility

+65 62143233

China Facility

+86 20 87337907



Kapco Global
Aerospace Parts & Distribution Services

kapco-global.com